

PRODUCT NUMBER
SEE SHEET 2

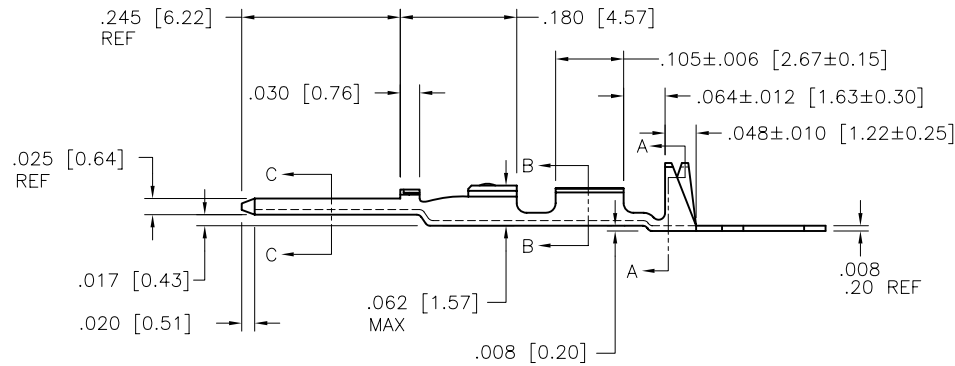

mat'l. code 3/4 HD BRASS CDA NO. 260				surface <input checked="" type="checkbox"/> tolerance		projection		product family PV TERMINAL	
ltr ecn no dr date				tolerances unless otherwise specified				title	
D	V41703	SAR	1994-11-30	angles	$.XX \pm .01/XX \pm 3$	INCH/MM		CTW MALE PIN	
E	V80946	LSS	1998-06-03	line	$.XXX \pm .005/XXX \pm 13$	scale 4/1		dwg no sheet 1 of 3 size	
F	V04-0056	VS	2004-02-17	$0^\circ \pm 2'$	$.XXXX \pm .0020/XXX \pm .051$			75653 A4	
G	V05-0467	HTB	2005-05-23	dr	S ROYER	1994-11-30		type CUSTOMER Drawing	
H	V06-0623	HTB	2006-06-28	ENGR	T.HANNA	1994-11-30			
J	V07-0218	HTB	2007-03-16	chr	T.HANNA	1994-11-30			
K	V08-0440	HTB	2008-10-09	appd	T.HANNA	1994-11-30			
sheet index	revision	K	K	K					
	sheet	1	2	3					

PRODUCT NO. AS REELED FOR APPLICATION MACHINES NOTE 5		WIRE AWG	WIRE BARREL			INSULATION BARREL			
RIGHT TO LEFT FEED	LEFT TO RIGHT FEED		A	B	C	D	E	F	
75653-001	75653-004	28-32	.054/1.37	.058/1.47	.011/0.28	.115/2.92	.105/2.67	.040/1.02	OBSOLETE
75653-001LF	75653-004LF	28-32	.054/1.37	.058/1.47	.011/0.28	.115/2.92	.105/2.67	.040/1.02	NOTE 7
75653-002	75653-005	22-26	.070/1.78	.065/1.65	.017/0.43	.139/3.53	.120/3.05	.050/1.27	OBSOLETE
75653-002LF	75653-005LF	22-26	.070/1.78	.065/1.65	.017/0.43	.139/3.53	.120/3.05	.050/1.27	NOTE 7
75653-003	75653-006	18-20	.104/2.64	.104/2.64	.021/0.53	.139/3.53	.120/3.05	.050/1.27	OBSOLETE
75653-003LF	75653-006LF	18-20	.104/2.64	.104/2.64	.021/0.53	.139/3.53	.120/3.05	.050/1.27	NOTE 7

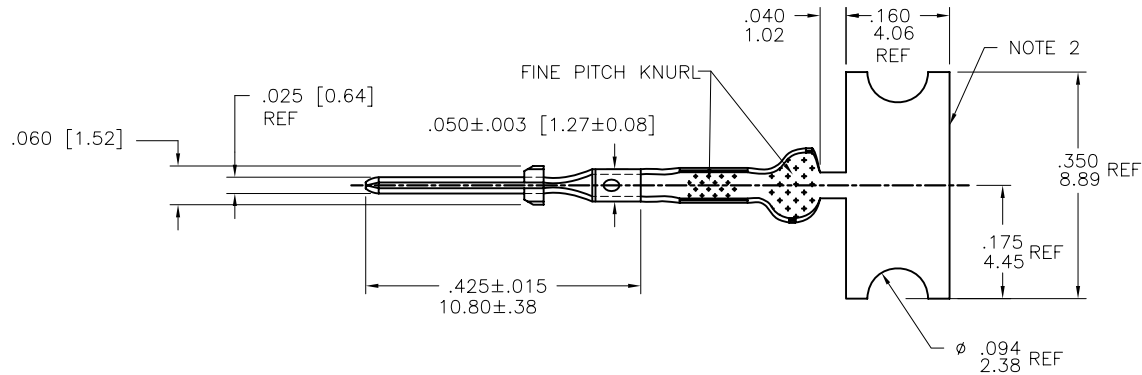
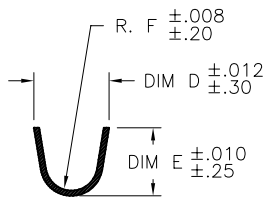

SECTION A-A
SCALE 2:1

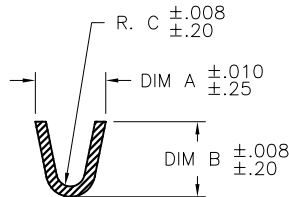

SECTION B-B
SCALE 2:1

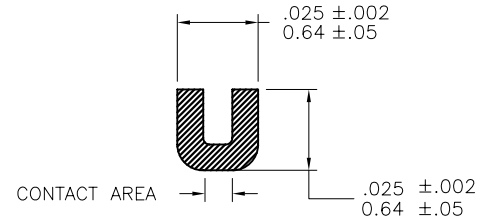

SECTION C-C
SCALE 5:1

NOTES:

- PLATING: 100μ"/2.54μ SnPb MINIMUM PRE-PLATED (OBSOLETE)
P/N WITH LF SUFFIX: 100μ"/2.54μ Sn MINIMUM PRE-PLATED
- FOR MANUFACTURING PURPOSES ONLY.
- PART MAY BE USED WITH MINI-LATCH HSG.
- APPLICABLE SPECIFICATIONS:
A. BUS-12-098: PRODUCT SPECIFICATION
B. TA-211: CRIMP SPECIFICATION
- PART NUMBERS WITH AN LF SUFFIX MEET EUROPEAN UNION DIRECTIVES AND OTHER COUNTRY REGULATIONS AS DESCRIBED IN GS-22-008.
- THIS PRODUCT IS NOT INTENDED TO BE EXPOSED TO MANUFACTURING SOLDER PROCESSES.
- THIS PRODUCT HAS 100% TIN PLATING IN THE INTERFACE AND HAS NOT BEEN TESTED FOR WHISKER GROWTH IN ALL INTERCONNECT ENVIRONMENTS.
- PACKAGE QUANTITY: 8000 PER REEL

mat'l. code 3/4 HD BRASS CDA NO. 260		surface ✓		tolerance tolerances unless otherwise specified		projection INCH/MM		product family PV TERMINAL	
ltr	ecn no	dr	date	angles	inches	mm	scale	title CTW MALE PIN	
K				0° ±2'	.XX ±.01/XX±3	.XXX ±.005/XXX±13	4/1	dwg no 75653	
					XXXX ±.0020/XXX±.051			sheet 2 of 3 size A4	
		dr	S ROYER	1994-11-30	FCI		type CUSTOMER Drawing		
		enr	T.HANNA	1994-11-30					
		chr	T.HANNA	1994-11-30					
		appd	T.HANNA	1994-11-30					
sheet index	revision sheet								

PRODUCT NUMBER
SEE SHEET 2

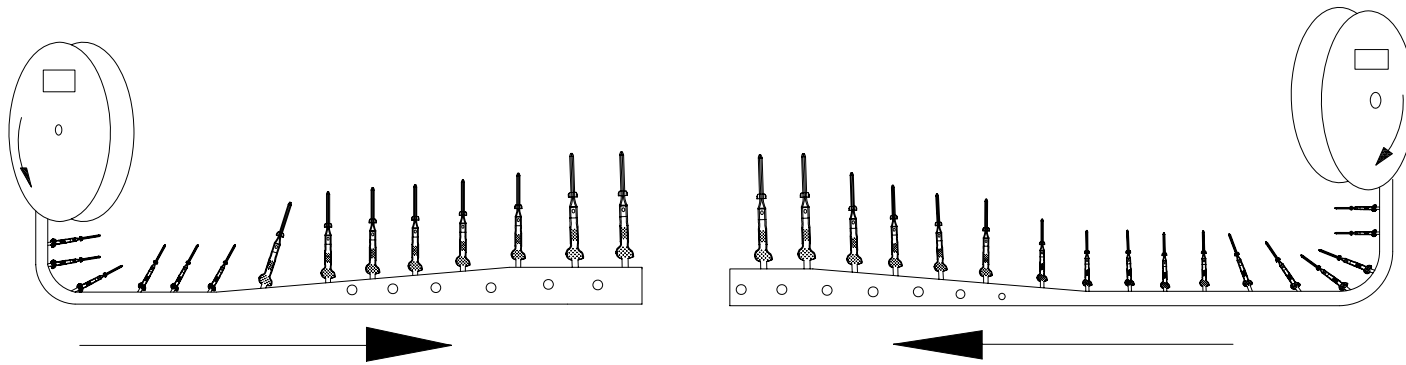

Unreeling Direction
Left to Right Into
Applicator

Unreeling Direction
Right to Left Into
Applicator

mat'l. code 3/4 HD BRASS CDA NO. 260		surface <input checked="" type="checkbox"/>	tolerance	projection	product family PV TERMINAL
ltr	ecn no	dr	date	tolerances unless otherwise specified	title CTW MALE PIN
k				angles $\frac{1}{16}$.XX ±01/X±3 XXX ±005/XX±13	INCH/MM
				0° ±2° .XXXX ±0020/XXX±051	scale 1:1
		dr	H. SUNDY	2004-02-17	dwg no
		engr	H. SUNDY	2004-02-17	75653
		chr	H. SUNDY	2004-02-17	sheet 3 of 3
		appd	H. SUNDY	2004-02-17	size A4
sheet index	revision sheet				type CUSTOMER Drawing